



# 箱式变压器

Pad-mounted Transformer

**QRE** 杭州钱江电气集团股份有限公司  
Hangzhou Qiantang River Electric Group Co., Ltd.

地址：中国杭州市萧山钱江电气科技工业园	Add: Qian Tang River Electric Science & Technology Industrial Zone, XiaoShan District, Hangzhou, China
邮编：311243	Post code: 311243
电话：0571-82583188 82582309	Tel: +86-571-82583188, 82582309
传真：0571-82582108 82582877	Fax: +86-571-82582108, 82582877
电子邮件：qre@qre.com.cn; intl@qre.com.cn	E-mail: qre@qre.com.cn; intl@qre.com.cn
网址：www.qre.com.cn	Web: www.qre.com.cn



# 目录

## CONTENTS

产品概述 Product Overview	2
产品特点 Product Characteristic	
型号说明 Model Coding	3
正常使用环境条件 Ambient Condition	
箱变结构布置示意图 Arrangement inside the Pad-mounted Transformer	4
熔断器 Fuses	5
负荷开关 Load break switch	
主要技术性能 Technical parameters	6
箱式变压器基础图 The Foundation Diagram of Pad-mounted Transformers	7
技术参数 Technical Parameters	8
高压电气接线方案 Proposal of HV electrical wiring	9
低压装置电气接线图方案（常规） Proposal of LV electrical wiring (Standard)	11
产品应用领域及销售业绩 Applications & Sales Reference	12
服务承诺 Service Guarantee	13
订货需知 Order Instructions	14

# 箱式变压器

## Pad-Mounted Transformer

### 产品概述

SB□-M系列箱式变压器（以下简称箱变），不同于国内通常的电力变压器，它将变压器器身、高压负荷开关、熔断器等保护元件都浸在绝缘液体内，并采用高燃点绝缘液（燃点 $>312^{\circ}\text{C}$ ），能安装在防火、防爆要求很高的场合。并能满足用户计量，无功补偿，低压分路等各种配置要求。

产品符合GB1904标准，同时按照机械部行业标准JB/T10217《组合式变压器》要求生产。该系列箱变具有输出能力强、噪声低、损耗少、体积小、结构紧凑、安装灵活方便、安全可靠等特点。

### 产品特点

1. 结构紧凑，体积小，安装灵活、方便。
2. 全绝缘结构，全密封，可靠保证人身安全。
3. 采用双熔丝保护，降低运行成本，插入式熔断器熔丝为双敏熔丝（温度、电流）。
4. 既可用于终端系统，也可用于环网系统。
5. 高压进线采用电缆插接件结构，具有隔离开关的特点，操作方便，灵活。
6. 变压器为三相三柱结构，铁心采用阶梯接缝（Step-Lap）工艺，因此噪声低、损耗小、抗短路和过载能力强。
7. 采用高燃点绝缘油，外表经“三防”和阴极电泳粉末涂装处理，可适用于各种恶劣环境。

### Product Overview

SB□-M series Pad-Mounted Transformer is the transformer that active body of transformer, HV load switches, fuses and other protection devices are immersed in insulating liquid. If high ignition insulating liquid (ignition point  $>312^{\circ}\text{C}$ ) applied, the transformer could be used in ambient conditions where higher demand for against fire and explosion required. The transformer could be customized to meet user's measurement, reactive power compensation, low-voltage shunt and other requirements.

The transformer complies with GB1904 standard, and at the same time in line with part of JB/T10217 standard. The transformer has advantages in output capability, low noise, low loss, small size, compact structure, easy to install, reliable and so on.

### Product Characteristic

1. Compact, Small size, Installation flexibility, convenient.
2. Insulation structure, totally enclosed, Guarantee the personal safety.
3. Use dual fuse protection, Reduce operating costs, Plug-in fuse's fuse is UNIKA fuse (temperature, current).
4. Can be used for terminal systems, can also be used for ring network system.
5. High Voltage Line use Cable connector construction, with the characteristics of isolating switch.
6. Three-phase three-pillar structure for transformer, magnet core use Step-Lap technology, so noise is low, loss is small, Anti-short circuit and overload ability is strong.
7. Use high-lighted insulation oil, processing by the "three defenses" and Cathodic electrophoretic coating powder, Applicable to kinds of harsh environment.



型号说明 Model Coding

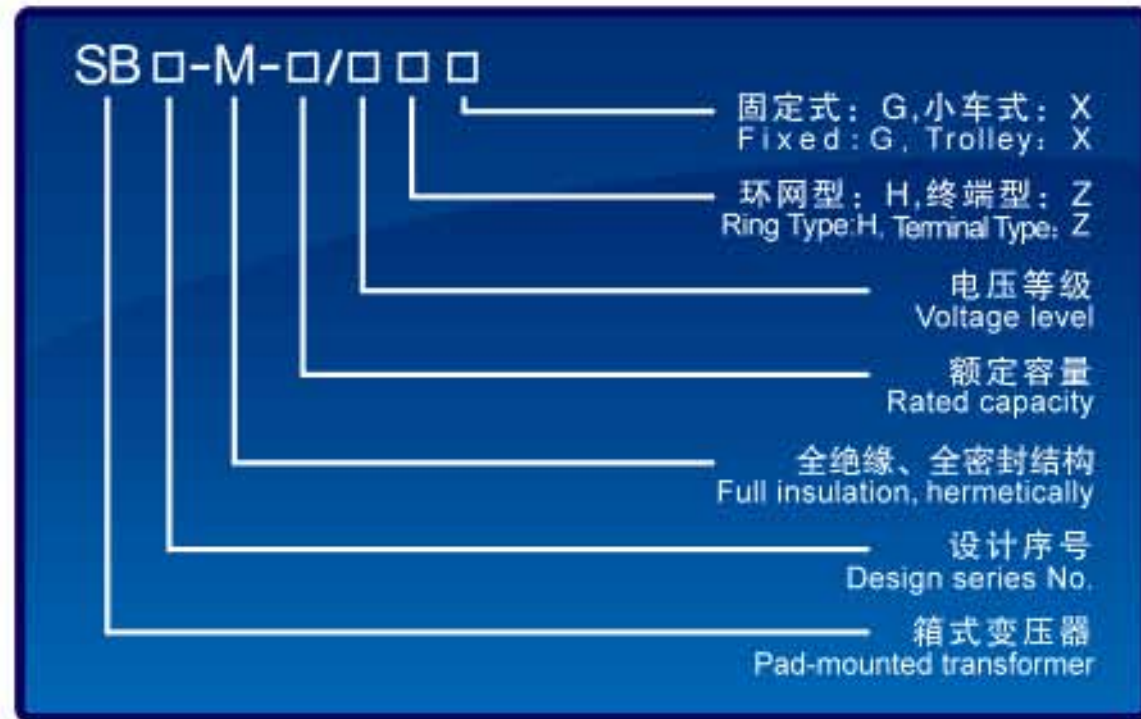

正常使用环境条件 Ambient Condition

- |                                  |  |
|----------------------------------|--|
| 1. 周围空气温度最高不超过40℃，最低不低于-25℃。     | 1. Ambient air temperature $\leq 40^{\circ}\text{C}$ , but $\geq -25^{\circ}\text{C}$ .                |
| 2. 海拔高度不超过1000m。                 | 2. Altitude $\leq 1000\text{m}$ .a.b.s.l.  |
| 3. 空气湿度不大于90% (+20℃)。            | 3. Humidity $\leq 90\%$ (+20℃).  |
| 4. 户外风速不超过35m/s。                 | 4. Outdoor wind speed $\leq 35\text{m/s}$ .  |
| 5. 无导电尘埃，无爆炸危险，无腐蚀危险，无腐蚀金属的气体场所。 | 5. In sites of no conductive dust, no risk of explosion, no corrosion risk, no corrosive gas to metal. |
| 6. 垂直倾斜不超过3°，无剧烈振动及无冲击的场所。       | 6. Vertical tilt $\leq 3^{\circ}$ , no severe vibration and shock-free place                           |
| 7. 特殊使用条件可进行特殊设计。                | 7. Transformers for special conditions can be specially designed.                                      |

箱变结构布置示意图 Arrangement inside the Pad-mounted Transformer

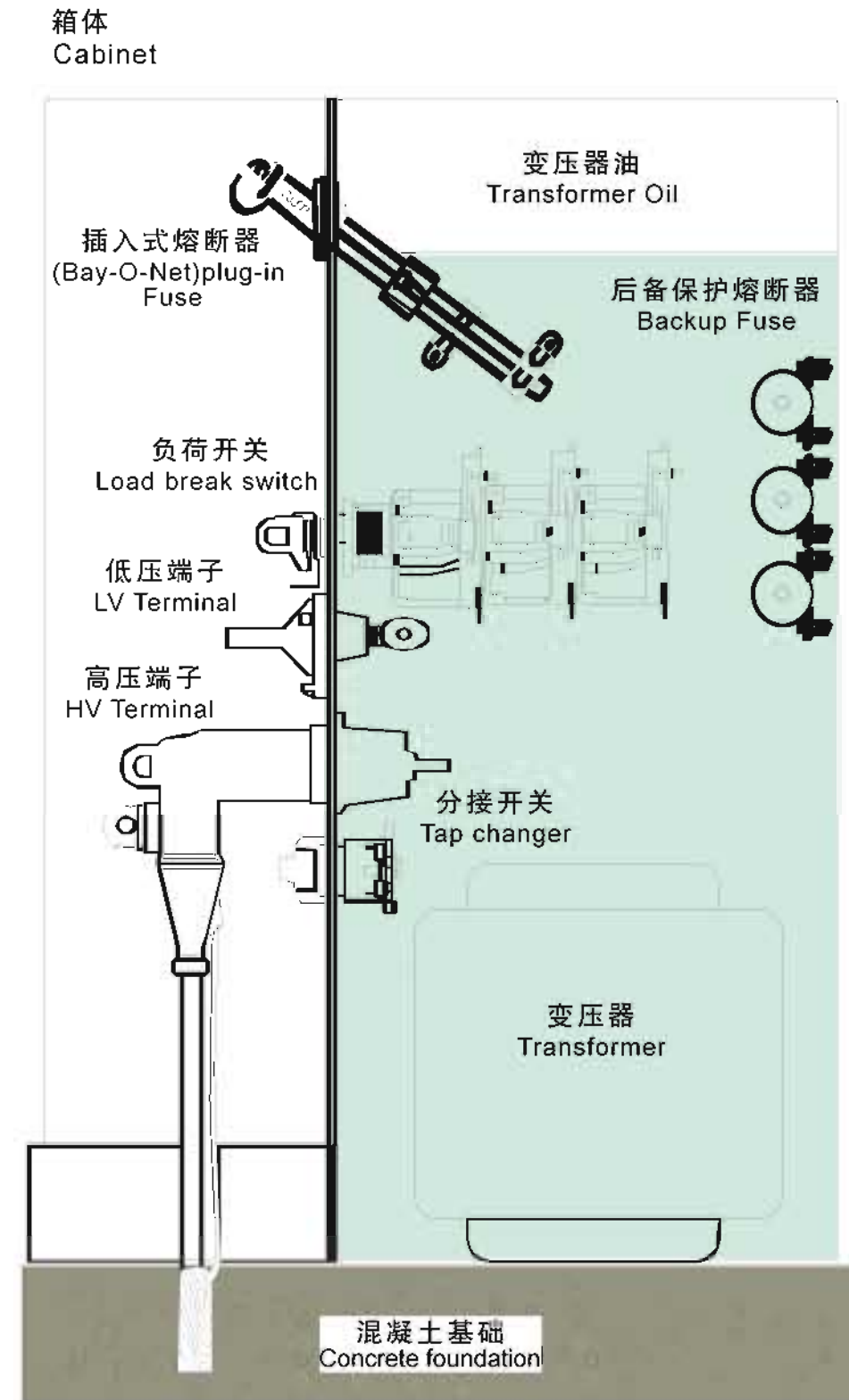

箱变结构布置示意图 Arrangement inside the Pad-mounted Transformer

## 熔断器 Fuses

箱变采用ELSP与BAY-O-NET熔断器串联保护，这种结构操作简单、方便，且经济、可靠。

ELSP是油浸式后备保护熔断器，只有在箱变内部发生故障时动作。BAY-O-NET熔断器则是在二次侧发生故障或过负荷、油温偏高时才动作。

ELSP and Bay-O-Net in series protection is applied. This arrangement has advantages of simplicity, convenience economy and reliability. The ELSP oil-immersed backup fuse acts only when break-down occurs inside the cabinet whereas the Bay-O-Net fuse acts only when breakdown or overload takes place in secondary side, or the fluid temperature is too high.

## 负荷开关 Load break switch

油浸式负荷开关，具有操作机构功能并为三相联动，分为四位置、三位置和二位置形式，分别适用于环网和二路供电终端配电系统，可完成负荷开断和关合操作。由于其三相联动，可以有效地降低铁磁共振。

The Oil-immersed Load Switch, with operating control and three-phase linkage and types of four, three and two positions, is applicable to load break and in ring main and two-way power supply systems. The gang operation of three phases can effectively reduce ferrromagnetic resonance.



后备保护熔断器  
ELSP fuses



插入式熔断器  
Bay-O-Net plug-in fuses

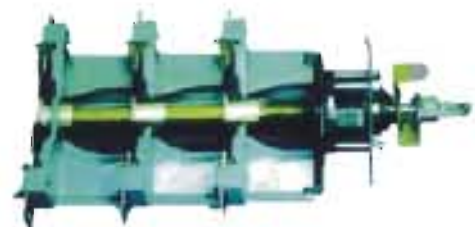

负荷开关  
Load break switch

## 主要技术性能 Technical parameters

序号 No.	名称 Description	单位 Unit	高压侧 HV side	变压器 Transformer	低压侧 LV side
1	额定容量 Rated capacity	kVA		30-1600	
2	额定电压 Rated voltage	kV	10		0.4
3	最高工作电压 Rated maximum working voltage	kV	12		
4	高压分接范围 Tapping range			$\pm 5\% \pm 2 \times 2.5\%$	
5	联结组别 Vector group			Yyn0、Dyn11	
6	额定电流 (元件) Rated current (component)	A	15-560		50-3200
7	短时耐受电流 Rated short-term withstanding current	kA	12.5, 16, 20		15-75
8	短时耐受时间 Rated short-term withstanding time	S	2		1
9	峰值耐受电流 Rated peak withstanding current	kA	31.5, 40		30-63
10	工频耐压 Power frequency withstanding voltage	kV	42	35	
11	冲击耐压 Impulse withstanding voltage	kV	75	75	
12	高压限流熔断器额定开关电流 HV fuse rated current	kA	50		
13	后备保护熔断器 Backup fuse	A		100、125	
14	防护等级 Protection level		IP33	全密封	IP33
15	环境温度 Ambient temperature	℃	-20~+40	-20~+40	-20~+40
16	额定频率 Rated frequency	Hz	50	50	50
17	噪声水平 Sound level	dB	≤ 55	≤ 55	≤ 55

# 箱式变压器基础图

## The Foundation Diagram of Pad-mounted Transformers

### 小车式基础图

Foundation diagram of Trolley type

kVA mm	80-250	315	400	500	630	800	1000	1250
L	615	635	645	655	655	700	715	740
a	300 (高压环网, 低压用1160小车时需分别加)				300 (Add separately when H.V ring system. L.V applies 1160 trolley)			
b	800小车为450, 960小车为550				800:trolley 450; 960:trolley 550			

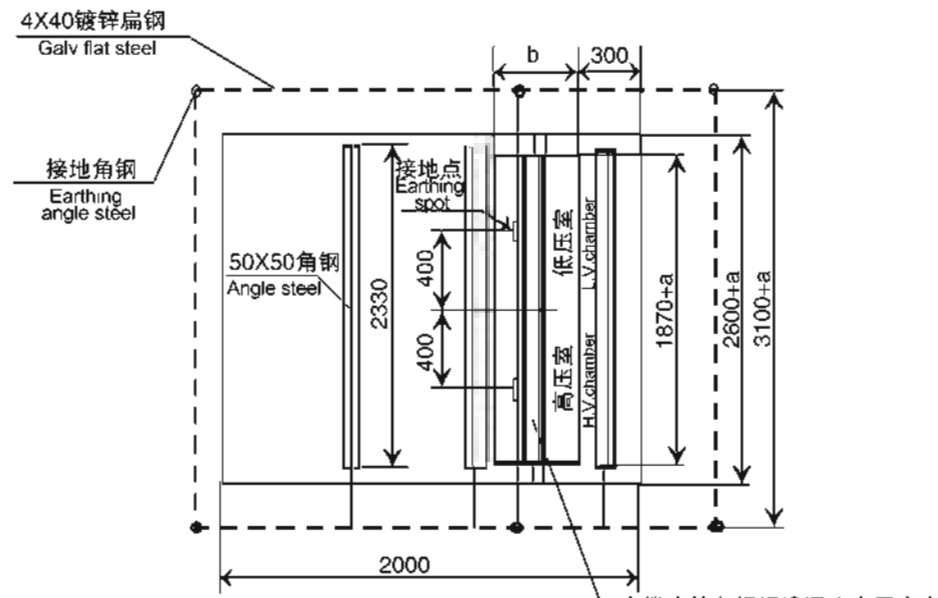
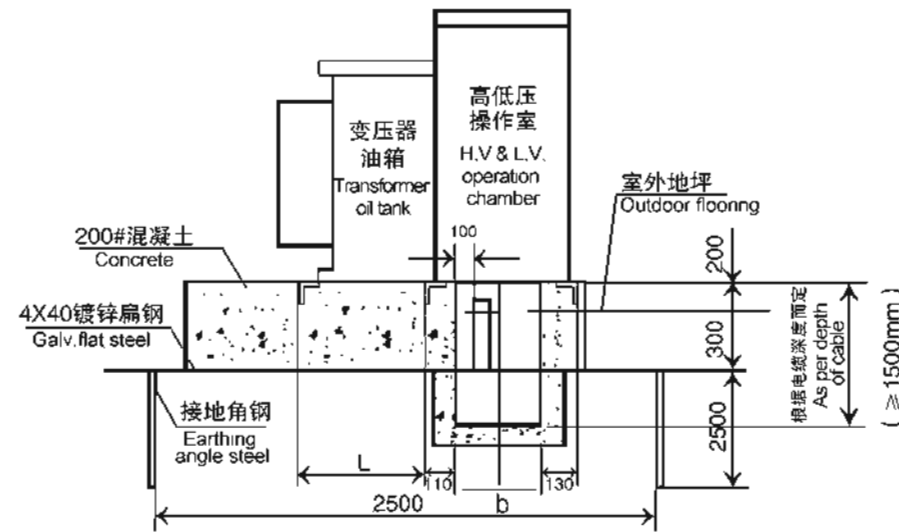

Depth of angle steel for clamping cable as per client's requirement

# 技术参数

## Technical Parameters

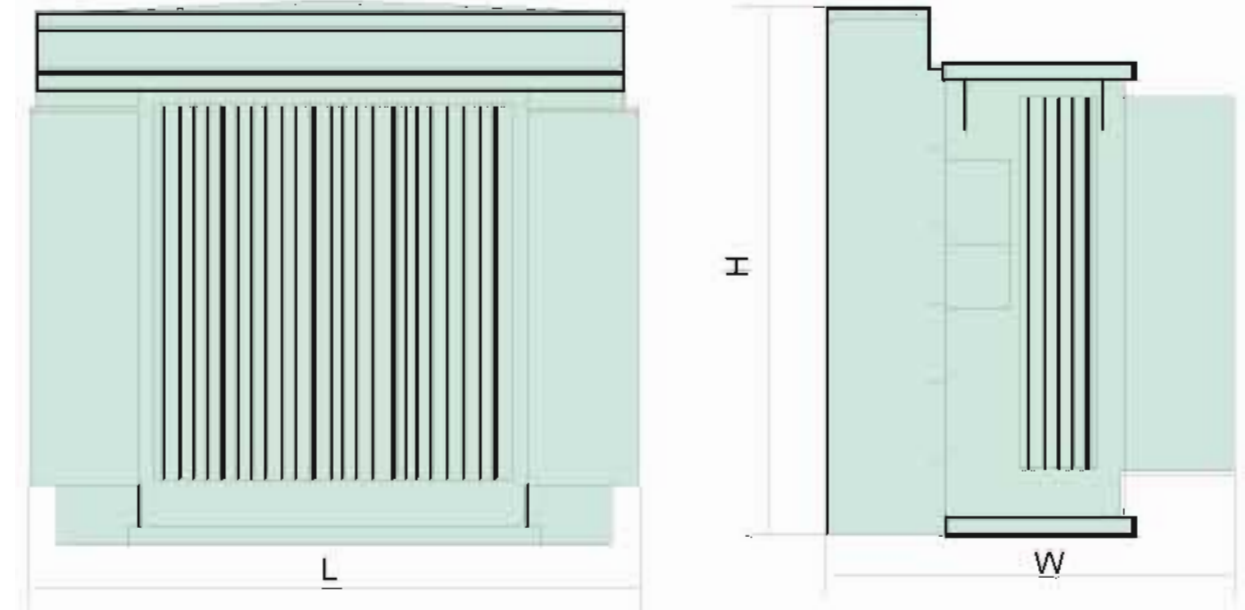

额定电压 Rated voltage: 6, 6.3, 10, 10.5/0.4kV  
 联结组标号 Vector group: Yyn0, Dyn11

表一 Chart 1

型号 Model	容量 Capacity	损耗 (kW) Loss		空载电流 (%) No-load current	短路阻抗 (%) Short-circuit impedance	重量 (kg) Weight	外形尺寸 长X宽X高 (mm) Overall dimension LxWxH		
		空载 No-load	负载 Load				固定安装 Fixed installation	小车安装 Trolley installation	车宽 Trolley width
SB10-M-30/10	30	0.11	0.63	1.8	4	1250	1865x1115x1735	2230x1345x1935	960
SB10-M-50/10	50	0.15	0.91	1.5		1290	1865x1115x1735	2230x1345x1935	
SB10-M-63/10	63	0.18	1.09	1.5		1370	1865x1115x1735	2230x1345x1935	
SB10-M-80/10	80	0.20	1.31	1.2		1420	1865x1160x1735	2230x1390x1935	
SB10-M-100/10	100	0.23	1.58	1.0		1540	1865x1160x1735	2230x1390x1935	
SB10-M-125/10	125	0.27	1.89	0.9		1580	1865x1170x1735	2230x1400x1935	
SB10-M-160/10	160	0.31	2.31	0.8		1610	1865x1220x1735	2230x1450x1935	
SB10-M-200/10	200	0.38	2.73	0.7		1710	1865x1250x1735	2230x1480x1935	
SB10-M-250/10	250	0.46	3.20	0.6		1770	1865x1330x1735	2230x1560x1935	
SB10-M-315/10	315	0.54	3.83	0.6		1920	1865x1370x1735	2230x1600x1935	
SB10-M-315/10	400	0.65	4.52	0.5		2160	1865x1440x1805	2230x1670x1935	
SB10-M-500/10	500	0.78	5.41	0.5		2450	1865x1410x1805	2230x1640x1935	
SB10-M-630/10	630	0.92	6.20	0.5		2680	1865x1450x1860	2230x1680x1935	
SB10-M-800/10	800	1.12	7.50	0.4		3070	1935x1500x1860	2230x1730x1935	
SB10-M-1000/10	1000	1.32	10.3	0.4	3660	2100x1520x2035	2230x1750x1935		
SB10-M-1250/10	1250	1.56	12.0	0.4	4130	2230x1540x2035	2230x1770x1935		

型号 Model	容量 Capacity	损耗 (kW) Loss		空载电流 (%) No-load current	短路阻抗 (%) Short-circuit impedance	重量 (kg) Weight	外形尺寸 (长X宽X高) [mm] Overall dimension (L×W×H)		
		空载 No-load	负载 Load				固定安装 Fixed installation	小车安装 Trolley installation	车宽 Trolley width
SB11-M-30/10	30	0.10	0.60	1.8	4	1250	1865X1115x1735	2230x1345x1935	960
SB11-M-50/10	50	0.13	0.87	1.5		1290	1865x1115x1735	2230x1345x1935	
SB11-M-63/10	63	0.15	1.09	1.5		1370	1865x1115x1735	2230x1345x1935	
SB11-M-80/10	80	0.18	1.25	1.2		1420	1865x1160x1735	2230x1390x1935	
SB11-M-100/10	100	0.20	1.50	1.0		1540	1865x1160x1735	2230x1390x1935	
SB11-M-125/10	125	0.24	1.80	0.9		1580	1865x1170x1735	2230x1400x1935	
SB11-M-160/10	160	0.27	2.20	0.8		1610	1865x1220x1735	2230x1450x1935	
SB11-M-200/10	200	0.33	2.60	0.7		1710	1865x1250x1735	2230x1480x1935	
SB11-M-250/10	250	0.40	3.05	0.6		1770	1865x1330x1735	2230x1560x1935	
SB11-M-315/10	315	0.48	3.65	0.6		1920	1865x1370x1735	2230x1600x1935	
SB11-M-400/10	400	0.57	4.30	0.5	2160	1865x1440x1805	2230x1670x1935		
SB11-M-500/10	500	0.68	5.10	0.5	2450	1865x1410x1805	2230x1640x1935		
SB11-M-630/10	630	0.81	6.20	0.5	2680	1865x1450x1860	2230x1680x1935		
SB11-M-800/10	800	0.98	7.50	0.4	3070	1935x1500x1860	2230x1730x1935		
SB11-M-1000/10	1000	1.15	10.3	0.4	3660	2100x1520x2035	2230x1750x1935		
SB11-M-1250/10	1250	1.36	12.0	0.4	4130	2230x1540x2035	2230x1770x1935		

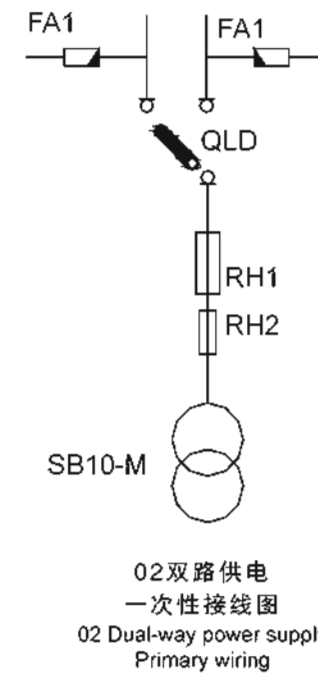

FA1: 高压避雷器  
QLD: III位置负荷开关  
RH1: 后备熔断器  
RH2: 插入式熔断器  
SB10-M: 箱式变压器

说明  
通A网: A网与变压器接通  
通B网: B网与变压器接通  
断开: A、B网与变压器断开

FA1: HV Surge Arrester  
QLD: III position load switch  
RH1: Backup fuse  
RH2: Plug-in fuse  
SB10-M: Pad mounted transformer

Notes  
Connect network A: Connect network A and transformer  
Connect network B: Connect network B and transformer  
Break: Break the connection of network A, B with transformer

高压电气接线方案 Proposal of HV electrical wiring

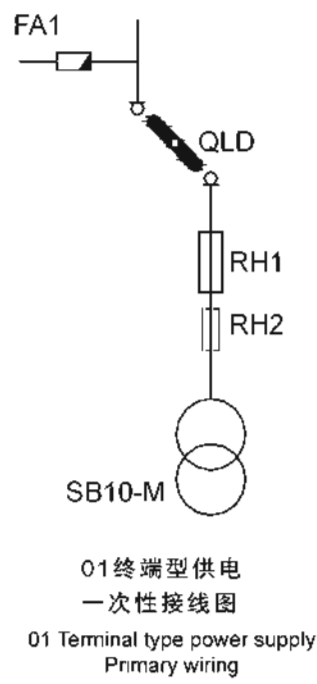

FA1: 高压避雷器  
QLD: II位置负荷开关  
RH1: 后备熔断器  
RH2: 插入式熔断器  
SB10-M: 箱式变压器

说明  
断开: 与变压器断开  
接通: 与变压器接通

FA1: HV Surge Arrester  
QLD: II position load switch  
RH1: Backup fuse  
RH2: Plug-in fuse  
SB10-M: Pad mounted transformer

Notes  
Break: Break from transformer  
Connect: Connect to transformer

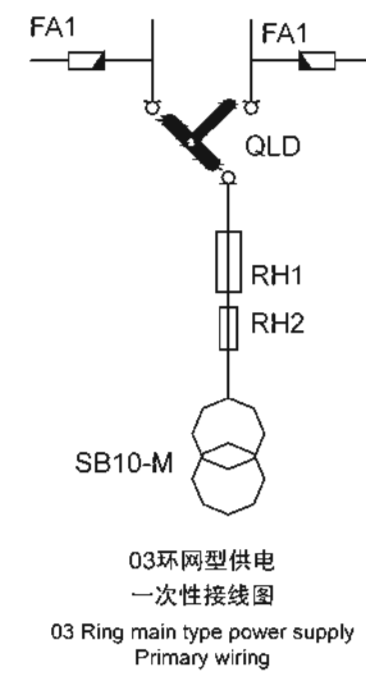

FA1: 高压避雷器  
QLD: IV位置负荷开关  
RH1: 后备熔断器  
RH2: 插入式熔断器  
SB10-M: 箱式变压器

说明  
接入环网: A、B网与变压器接通, A网与B网接通  
通A网: A网与变压器接通  
通B网: B网与变压器接通  
脱离环网: A、B网与变压器断开, A网与B网接通

FA1: HV Surge Arrester  
QLD: IV position load switch  
RH1: Backup fuse  
RH2: Plug-in fuse  
SB10-M: Pad mounted transformer

Notes  
Connect Ring Main network: Connect network A, B with transformer; connect network A and B  
Connect network A: Connect network A and transformer  
Connect network B: Connect network B and transformer  
Break Ring Main network: Break network A, B with transformer; connect network A and B

## 低压装置电气接线图方案 (常规) Proposal of LV electrical wiring (Standard)

QF: 主开关 (可选隔离开关、智能型万能式低压断路器及塑料外壳式断路器等开关)

TA1: 计量互感器 (可选用直接式及串心式, 符合计量要求的电流互感器)

TA2: 测量互感器 (推荐选用串心式电流互感器, 如BH-0.66型)

TA3: 取样互感器 (推荐选用串心式电流互感器, 如BH-0.66型)

QF1~n: 分路开关 (推荐选用塑料外壳式断路器)

QA: 微型开关 (S253S)

KM: 接触器 (CJ19C)

C: 电容器 (BSMJ-0.4)

F: 避雷器 (HY2.5W-0.28/1.3)

注: 1、配件可根据用户需要另行选择。

2、低压配置其他方案可根据用户要求生产。

QF: Main switch (selection of disconnecting switch, ACB and MCCB)

TA1: Metering transformer (selection of direct style and string heart-type, conforming to requirements of current transformer metering)

TA2: Measuring transformer (Recommend string heart-type current transformer like BH-0.66)

TA3: Sample transformer (Recommend string heart-type current transformer like BH-0.66)

QF1~n: Shunt switch (Recommend MCCB)

QA: Micro switch (S253S)

KM: AC Contactor (CJ19C)

C: Capacitor (BSMJ-0.4)

F: Surge arrester (HY2.5W-0.28/1.3)

Notes:

1. Client's special requirement for components can be satisfied

2. Other LV figuration can be met as per Client's requirement.

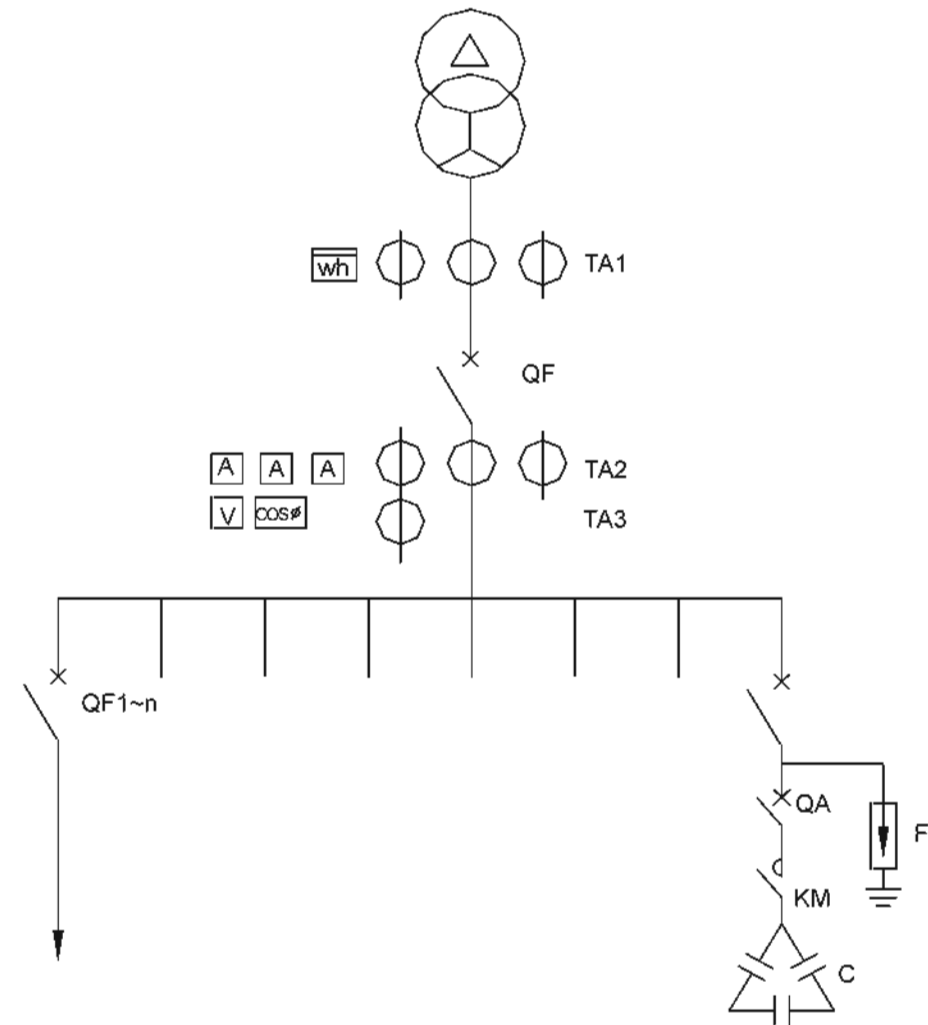

## 产品应用领域及销售业绩 Applications & Sales Reference

该系列箱变比传统的土建变电站投资少、占地小, 使用灵活方便, 能代替同类进口变压器, 既可用于户外、又可用于户内, 广泛用于城网改建, 以及高层建筑楼宇、住宅小区、工业园、商业中心、空港码头、学校、厂矿企业等配电场所。

Compared with conventional transformer, Pad Mounted Transformer demands less investment, small area, and more convenient. It is good substitute to similar imported Transformer. It is suitable for outdoor and indoor use. It is widely used in the urban power network, high-rise building, residential area, industrial park, commercial center, airport and sea port, school and so on.



公司以实现“国际一流的电气设备供应商”为发展愿景, 通过提供有价值、高质量的产品和服务, 满足客户的需求, 努力使钱江电气成为国内领先、国际上知名的电力电气设备供应商。

QRE tries to be a world-class and leading domestic electrical equipment supplier by providing valuable, high-quality products and services to satisfy customer's demands

(单位: 亿人民币)  
(Unit: 100 million CNY)

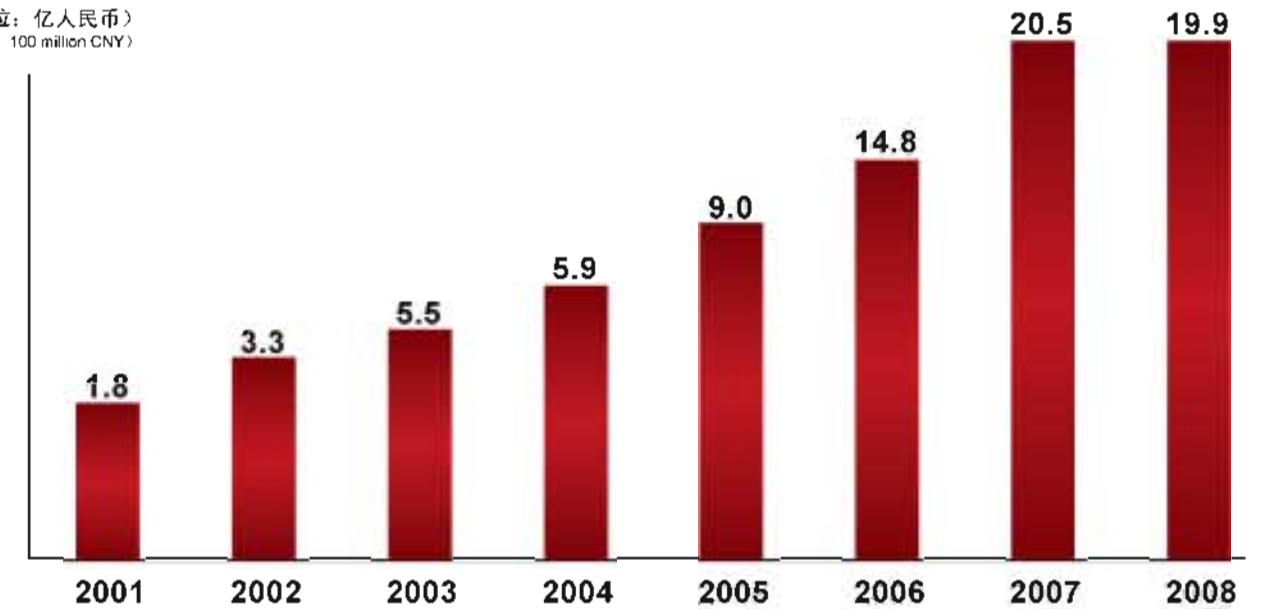



## 服务承诺

- 1.及时向顾客提供按合同规定的全部技术资料 and 图纸。有义务在必要时邀请顾客参与供方的技术设计审查。
- 2.按顾客要求的时间到现场进行技术服务，指导顾客按供方的技术资料 and 图纸要求进行安装、调试与整套试运及试生产。
- 3.对于顾客选购的与合同设备有关的配套设备，我方主动提供满足设备接口要求的技术条件和资料。
- 4.严格执行供需双方就有关问题召开会议会议纪要或签订的协议。
- 5.按合同规定为顾客举办有关设备安装、调试、使用、维护技术的业务培训班。
- 6.加强售前、售中、售后服务，把“24小时服务”、“超前服务”、“全过程服务”、“终身服务”贯彻在产品制造、安装、调试、修理的全过程。
- 7.随时满足顾客对备品备件的要求。

## Service Guarantee

- 1.To provide all technical information and drawings as per contract promptly. QRE is obliged to invite client, if necessary, to attend technical design review.
- 2.To carry out spot technical service as per client's schedule, offer guideness for installation and commissioning according to technical information and drawings.
- 3.For relevant auxillary equipment procured by customers, QRE will provide related technical information to meet requirement of equipment interface.
- 4.To execute stipulations in MOU or agreement signed by seller and buyer strictly.
- 5.To train staff from client for equipment installation, commissioning, application, maintenance as stipulated in the contract.
- 6.To reinforce pre-sales, mid-sales, after-sales service, to carry out "24-hour service", "service in advance", "overall process service", "lifelong service" in our manufacturing, installation, commissioning and maintenance.
- 7.To meet spare parts' requirement by customers at any time.

## 订货需知

- 1、产品型号、规格及数量。
- 2、高低压组成方案。
- 3、高压元件的产地（进口或国产）。
- 4、其它要求应订货时提出。

## Order Instructions

- 1.Model, norms and number.
- 2.Composition of high and low pressure.
- 3.Origin of high-voltage components(import or made in china).
- 4.Others.

■ 尊敬的客户朋友,如果您有服务需求,可以发送Email给我们,或者直接电话与我们联系:

用户服务中心:0571-82583638, 0571-82583088, 0571-82583928

传 真: 0571-82583618, 0571-82582309

Dear clients, if there is any enquiry or requirement, please feel free to send email: intl@qre.com.cn or make phone call directly to service center:

+86-571-82583638, 82583088, 82583928

Fax:+86-571-82583618, 82582309